

Testing and Evaluation Equipment

Table-Top Tester



EZ Test

High-Precision Universal Testers



AG-X (table-top type) 20 kN AG-X (floor type) 20 kN

Rubber and Plastic Testers



Capillary Rheometer Flow Tester CFT-500D Automatic Mooney Viscometer SMV-300

Global Support

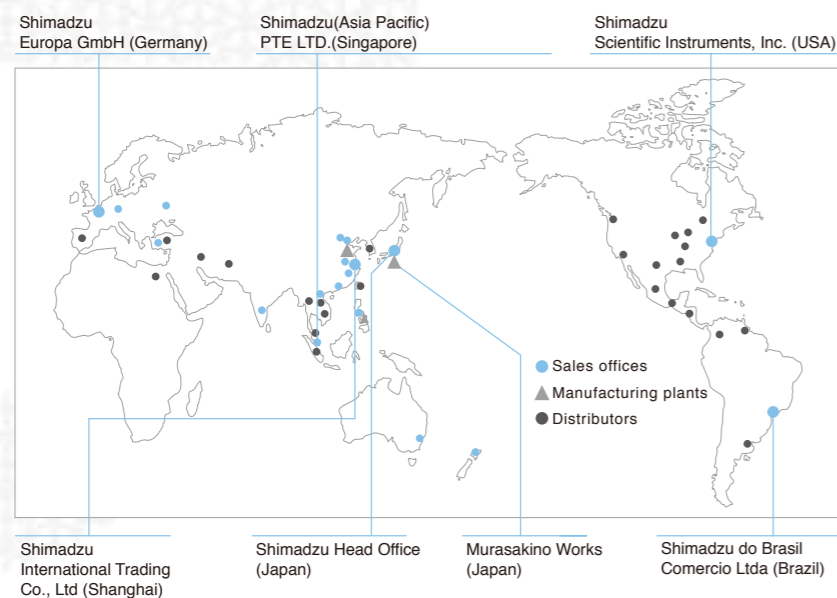

JQA-0376

Founded in 1875, Shimadzu Corporation, a leader in the development of advanced technologies, has a distinguished history of innovation built on the foundation of contributing to society through science and technology. We maintain a global network of sales, service, technical support and applications centers on six continents, and have established long-term relationships with a host of highly trained distributors located in over 100 countries. For information about Shimadzu, and to contact your local office, please visit our Web site at www.shimadzu.com



SHIMADZU CORPORATION. International Marketing Division
3. Kanda-Nishikicho 1-chome, Chiyoda-ku, Tokyo 101-8448, Japan
Phone: 81(3)3219-5641 Fax: 81(3)3219-5710
URL <http://www.shimadzu.com>

Printed in Japan 3295-01910-30ANS



Autograph AGS-X Series

Shimadzu
Table-Top Type
Precision Universal Tester



The contents of this brochure are subject to change without notice.

New AGS-X functions provide great

Autograph AGS-X Series

Shimadzu Table-Top Type Universal Testing Instruments

NEW Smarter Work Space

Everything you need in a standalone tester

- ✓ Open multi-table design → P.06
- ✓ New one-touch stroke limiters + safety guard → P.07
- ✓ Main operation panel to call up test methods from the PC → P.07
- ✓ Optional jog controller for convenient crosshead positional adjustments → P.07

NEW Even the Complex Becomes Easy

TRAPEZIUM LITE X software macros significantly enhance the efficiency of testing work.

- ✓ Macros automate saving and transfer of test results and report printing → P.11

NEW Convincing Specifications

Top-end machine performance from a table-top tester

- ✓ Guaranteed test force range: $\pm 0.5\%$ indicated value (from 1/500 to 1/1 load cell rating) → P.16
- ✓ Testing speed: 0.001 to 1,000 mm/minute → P.16
- ✓ Return speed: 1,500 mm/minute → P.16
- ✓ High-speed sampling: 1 msec → P.16

Contents

P 8 - Simply Concentrate on the Test Work

P 14 - Testing in Controlled Environments

P 10 - Simple Software Enhances Productivity

P 16 - Specifications

P 12 - Extension Measurements on Soft Plastics and Rubber

One-Touch Stroke Limiters



Pinch and slide; release to lock. One-touch stroke limiters **permit simple one-touch adjustment and firm locking** of the crosshead stroke limit positions.

Crosshead

Achieves 1,500 mm/minute return speed, significantly reducing the time required to conduct repetitive testing. Example: Time to return a distance of 250 mm is reduced from 40 s to 12 s. This would save one hour when testing 120 specimens.

Multipurpose Tray



Large space in front of the instrument. Perfect for placing jigs, arranging specimens, or taking notes.

Emergency Stop Button

Reliably cuts off power to the servo amplifier, **instantaneously stopping** crosshead movement in the event of an emergency.



New AGS-X functions provide great support for testing work.

One-Touch Stroke Limiters



Pinch and slide; release to lock. One-touch stroke limiters **permit simple one-touch adjustment and firm locking** of the crosshead stroke limit positions.

Crosshead

Achieves 1,500 mm/minute return speed, significantly reducing the time required to conduct repetitive testing. Example: Time to return a distance of 250 mm is reduced from 40 s to 12 s. This would save one hour when testing 120 specimens.

Multipurpose Tray



Large space in front of the instrument. Perfect for placing jigs, arranging specimens, or taking notes.

Emergency Stop Button

Reliably cuts off power to the servo amplifier, **instantaneously stopping** crosshead movement in the event of an emergency.



Safety Guard to Protect Against Flying Debris (option)



A vertically sliding safety guard is supplied. Opens easily with one hand. When the safety guard is open, an interlock function disables testing and return movement.

Load Cell

Over the range from 1/500 to 1/1 of the load cell rating, a single load cell that guarantees test force accuracy to $\pm 0.5\%$ of the indicated value* covers an extensive testing range. The load cell rated value is stored in the calibration cable and automatically recognized when the cable is connected.

* For high-precision type.

Jog Controller (option)

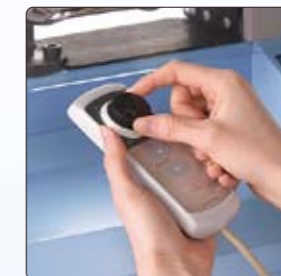

Allows hand-held control of the crosshead position. **The jog dial** makes fine positioning a breeze.

Main Operation panel

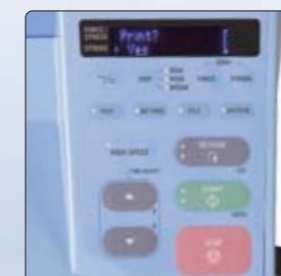

Conduct testing by calling up the test methods from TRAPEZIUM LITE X software. Naturally, AGS-X can be used as a standalone tester to test specimens using test methods created with the tester itself.

Now more convenient to use

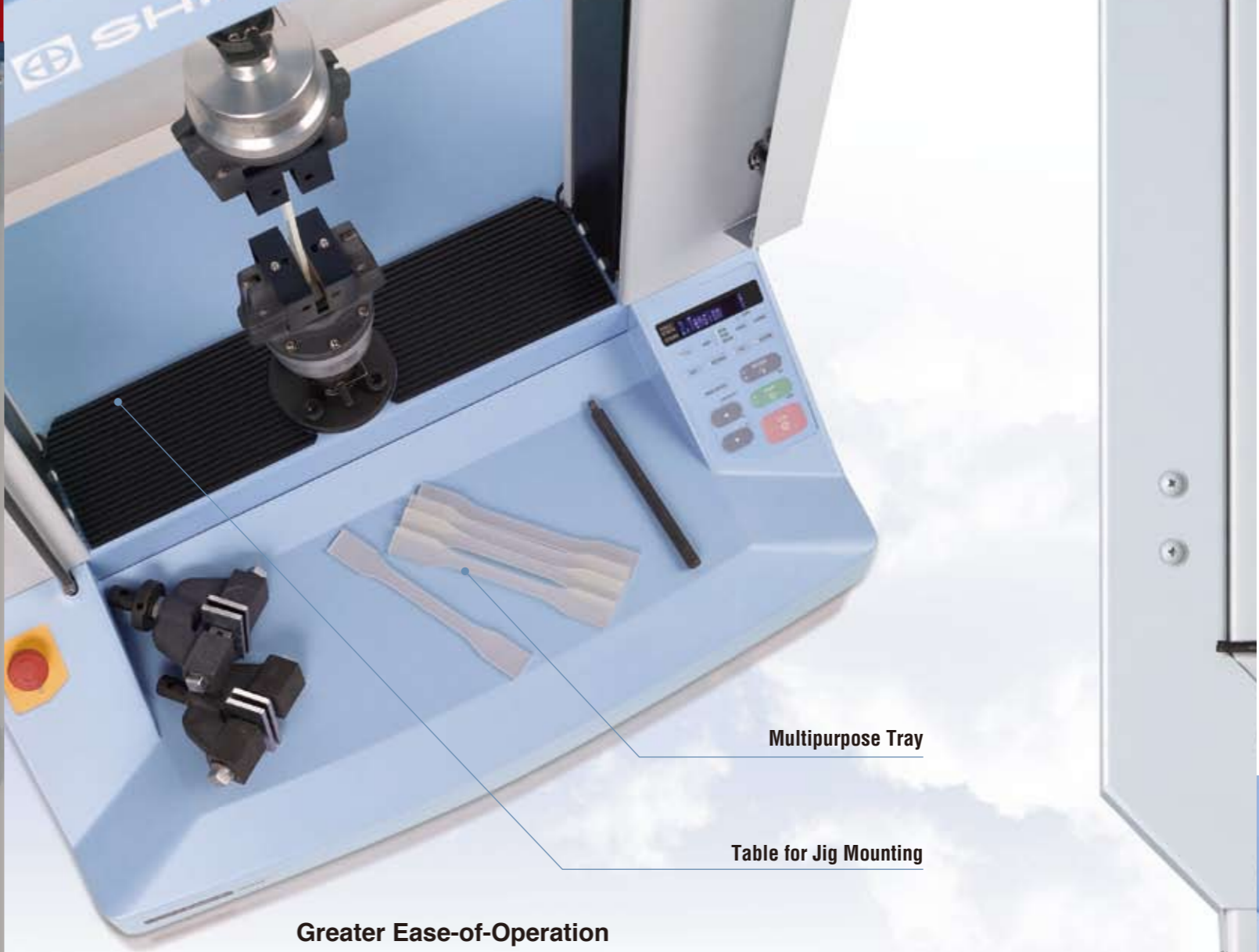

Multipurpose Tray

Table for Jig Mounting

Greater Ease-of-Operation

The heights of the multipurpose tray and table for jig mounting have been significantly lowered. Being a full 58 mm lower than on previous models, the multipurpose tray is at a comfortable working height. The open design of the multipurpose tray surface can accommodate a large number of test specimens and jigs.

Table height on previous models →

-58mm

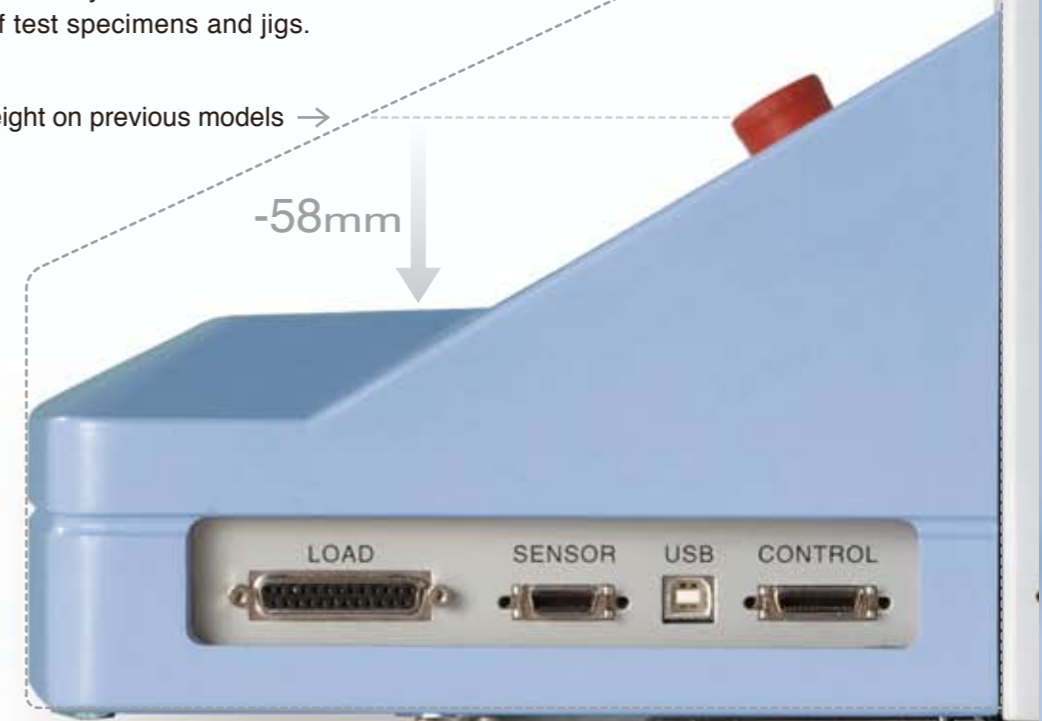



Multipurpose Tray

Table for Jig Mounting

Greater Ease-of-Operation

The heights of the multipurpose tray and table for jig mounting have been significantly lowered. Being a full 58 mm lower than on previous models, the multipurpose tray is at a comfortable working height. The open design of the multipurpose tray surface can accommodate a large number of test specimens and jigs.

Table height on previous models →

-58mm

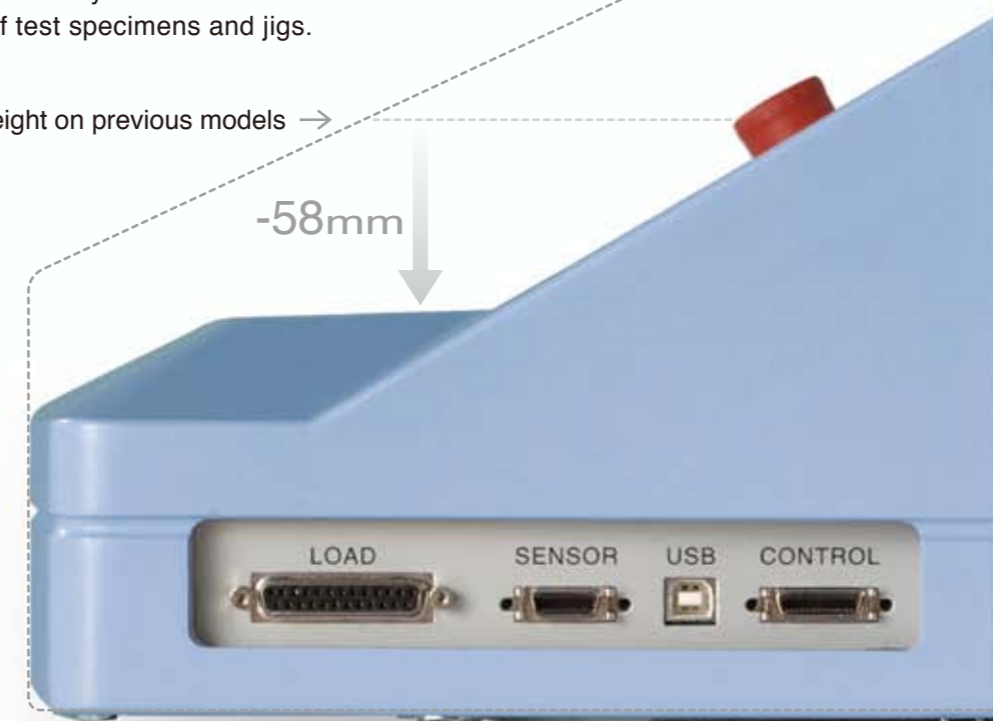

Precision Position Adjustments (Option)

The optional jog controller permits fine adjustments of the crosshead position without taking your eyes off the test space.



Simply Concentrate on the Test Work

There is no need to touch the mouse or keyboard.
 A close tie-up between the significantly improved functions of the AGS-X and the macros offered by the TRAPEZIUM LITE X software dramatically enhances the efficiency of repetitive testing operations.



Tester Operations

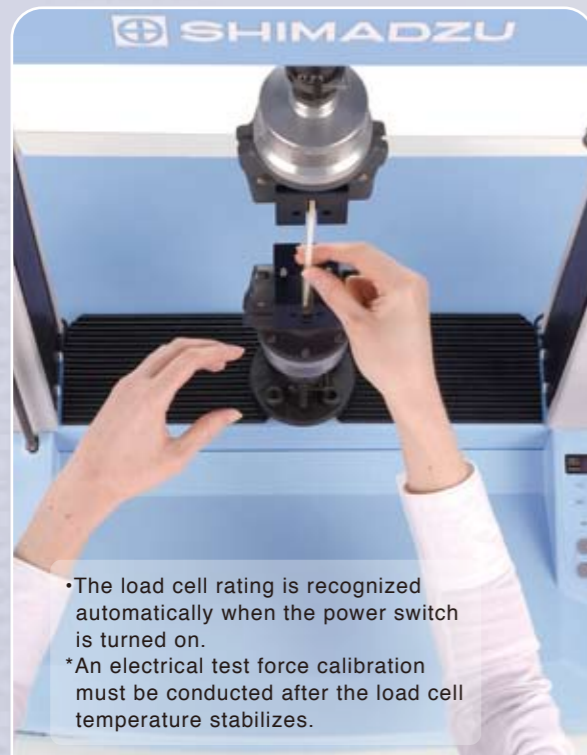

- The load cell rating is recognized automatically when the power switch is turned on.
- *An electrical test force calibration must be conducted after the load cell temperature stabilizes.

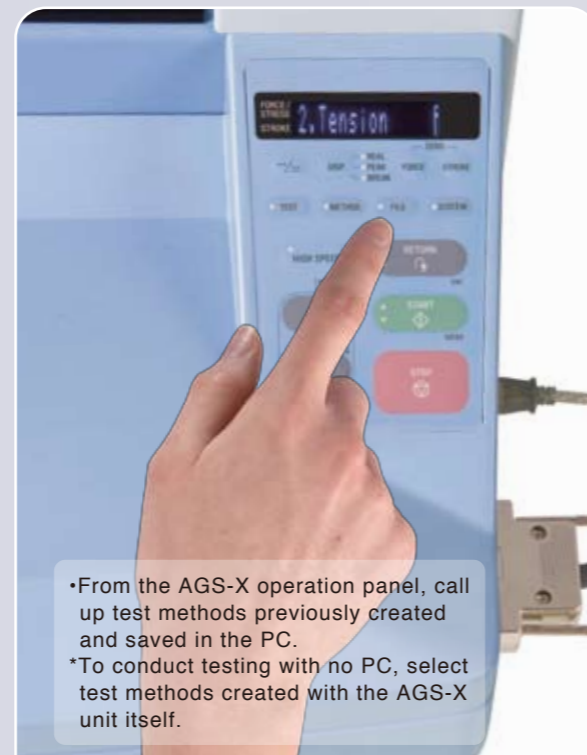

- From the AGS-X operation panel, call up test methods previously created and saved in the PC.
- *To conduct testing with no PC, select test methods created with the AGS-X unit itself.



- Simply press the START button to start the test.



Report printing Test data transmission

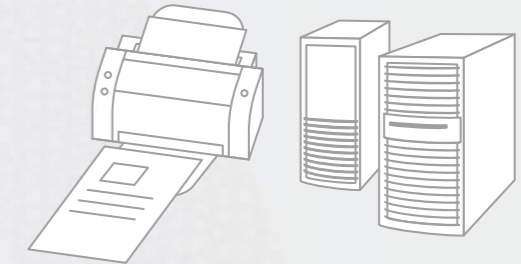

- *When a test (sub-batch) is complete, the test results can be automatically saved and printed. (Alternatively, reports can be printed when required from the AGS-X operation panel.) The test data can also be automatically transmitted to the administrator's PC.
- * A network environment is required to transmit test data.

PC Operations



Home page

- Simply press the PC POWER button to start the operating system, run TRAPEZIUM LITE X, and automatically bring up the home page.
- *Manual operation is also possible.



Test screen

- When the test conditions are called up using the AGS-X operation panel, the PC automatically displays the window to start testing.

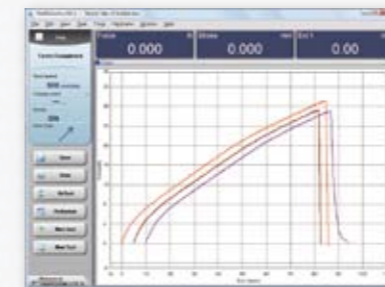

Test screen

- When the test starts, the test force and stroke are displayed on the PC screen.

Simple Software Enhances Productivity

Materials Testing Software



TRAPEZIUM LITE X is newly developed simple software for Autograph series testing machines. It boasts comprehensive new functions for more efficient testing.

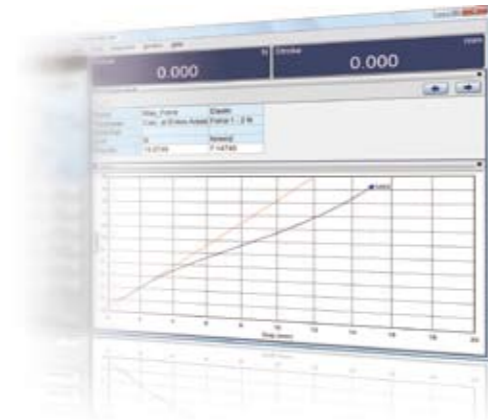

Quick Method List NEW
Makes Testing Easy
No mouse or keyboard required

Register often-used test methods to the Quick Method List to start testing instantly. The registered test methods can be directly selected or edited at the AGS-X tester, making testing easy even for users who find using a PC troublesome.



Simple Screen Layout
Few buttons ensure easily navigated operations
One-touch test method selection

As the number of displayed buttons is restricted according to the login authority, the operator uses very simple screen displays for operations.
 To start a test, simply select the test methods from a list.
 For a clearer display, just the required information can be selected for display during testing, such as the maximum size graph or the test results.

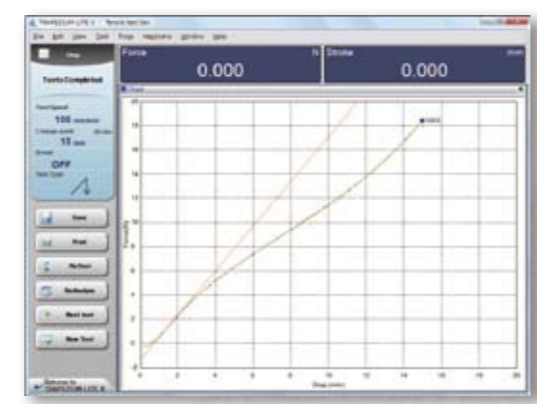

Macros Enhance Work Efficiency NEW
Just set up the test and start testing.
All tedious operations have been automated.

The sequence of operations frequently conducted after testing can be fully automated. Functions for coordinating with the AGS-X permit saving of test data and report generation and printing without touching a PC.

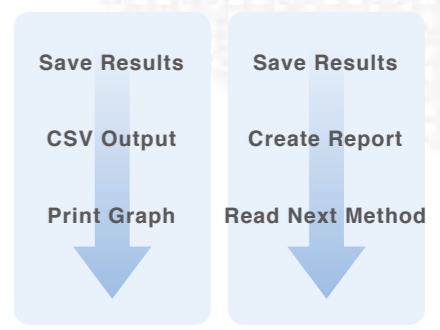
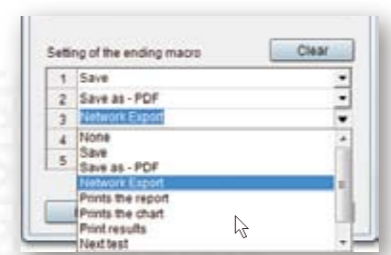

Examples of Macros

Supports Industry Standards
Recording convenient test method files
enables instant testing

Test method files for rubbers, plastics, and films that comply with JIS/ISO/ASTM standards are provided. The terminology and data processing items specified in the test standard are pre-registered in the respective test method file to permit smooth testing in compliance with the test standards.
 * The test method files supplied on the installation CD may not conform to the latest standards. Test results obtained using these test method files are not guaranteed.

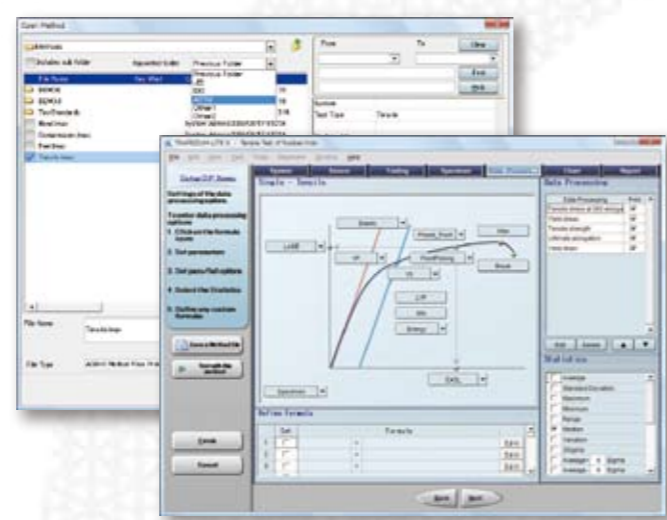

Statistical Process Control Functions
Effectively utilize daily test results.

Test results can be extracted and compiled over a fixed period to create histograms and XBar-R control charts. Statistics can be compiled on daily test results by date, by specimen, or by batch, and the statistical results displayed on screen.
 Text can be added to statistical information for printing or output to a pdf file.

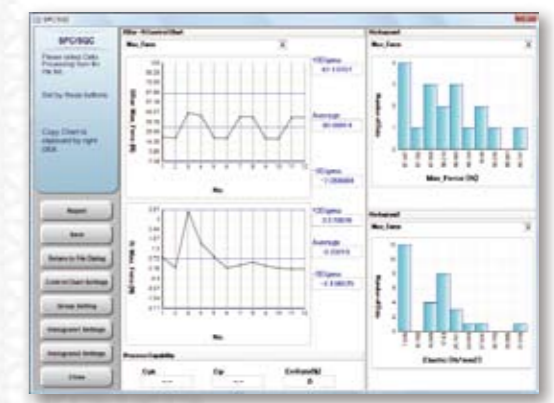

Extension Measurements on Soft Plastics and Rubber



- ① Tester Main Unit
- ② Extensometer for Soft Specimens
- ③ Pneumatic Flat Grips

Example: Combination with SES-1000 Extensometer for soft specimens
Offers easy and highly accurate measurements of gauge length elongation on highly elastic specimens. Ideal for long-stroke testing of plastics and rubber. Using pneumatic flat grips facilitates specimen loading and unloading to further improve testing efficiency.

Equipment Configuration	
① Tester Main Unit (Standard precision) AGS-1kNX STD kit	346-59003-11
② Extensometer for Soft Specimens SES-1000	346-51681-22
③ Pneumatic Flat Grips PFG-1kNA kit	346-53848-01

Grips Plastics Metals Lumber

For hard specimens
Non-shift Wedge Type Grips
MWG Series

Wedge action generates a large holding force from a small clamping force. The most popular type of grip.

Grips Plastics Rubber Textiles Cloth Paper

For low-slip specimens
Screw Type Flat Grips
SCG Series

Preset the position of one grip face according to the thickness or diameter of the specimen, and subsequently load and unload specimens by operating the other grip face only.

Grips Plastics Rubber Textiles Cloth Paper Film

For large numbers of tests
Pneumatic Flat Grips
PFG Series

Grip faces open and close by foot valve or foot switch operation. These grips can be interlocked with the tester (option). Maintain a constant clamping force, even if the specimen thickness decreases.

Extensometer Plastics Metals

For large numbers of tests
Automatic Extensometer
SIE Series

Automatic gauge position detection, gauge length setting, and arm clamping and unclamping to specimen.
* Requires TRAPEZIUM LITE X (option).

Extensometer Plastics Rubber Textiles Cloth Paper Film

For all specimen materials
Video Type Non-Contact Extensometer
DVE Series

Conducts gauge length elongation measurements on specimens, based on CCD camera images. Accurate elongation measurements over an extensive range.

Extensometer Plastics Metals

For hard specimens
Strain Gauge Type One-touch
Extensometer SSG-H Series

Lightweight, compact extensometer that can be attached or removed by a simple, one-touch operation.
* Requires external amplifier (option).

Replace Jigs for Compression or Bending Testing

Compression plate Plastics Metals Rubber Lumber

Compression Test

Fixed Type Compression Plate
General-purpose type with fixed upper and lower compression plates.

Spherical Seat Type Compression Plate
Upper compression plate has a spherical seat to apply a more uniform test force across the specimen surface.

Bending Jig Plastics

Three-Point Bending Test for Plastic

Three-Point Bending Test Jig for Plastic
Three-point bending test jig for plastics conforming to JIS, ISO, and ASTM standards. Replace the support set to accommodate different test specimen thickness standards.

Testing in Controlled Environments



Example: Combination with TCE-300 Compact Type Thermostatic Chamber.

Enables testing across a temperature range from -70°C to +280°C. Allows testing in reproducible operating environments.

Using the pull rod (extension connector rod included in the in-chamber tensile kit) allows the grips to be located inside the thermostatic chamber.

Equipment Configuration

① Tester Main Unit (Standard precision) AGS-1kNX STD Kit*	346-59042-11
② Compact Type Thermostatic Chamber TCE-N300	346-53936-17
③ Screw Type Flat Grips SCG-5kNA	346-52326-04
④ In-Chamber Tensile Kit For AGS1kN to 100N	346-53988-01

* Consult your Shimadzu representative if you wish to use the safety guard and thermostatic chamber together.

Thermostatic Chamber

Plastics Rubber Textiles Cloth Paper Films

For frequent low-temperature testing

Temperature Range -35 °C to +250 °C (TCRI)
-60 °C to +250 °C (TCR2)

Refrigerator Type Thermostatic Chamber TCR Series



Ideal for frequent low-temperature testing, as the temperature is reduced using a refrigerator. Models TCR-1 and TCR-2 accommodate different temperature ranges.
Heating: Heater Cooling: Refrigerator

Thermostatic Chamber

Plastics Rubber Textiles Cloth Paper Films

For testing over a wide temperature range

Temperature Range -180 °C to +320 °C (TCL-N)
-70 °C to +320 °C (TCL-C)
+50 °C to +320 °C (TCH)

Gas Jet Type Thermostatic Chamber TCL, TCH Series



Liquid nitrogen or carbon dioxide is injected to lower the temperature. Offers colder testing environments than the refrigerator type.
Heating: Heater Cooling: Liquid nitrogen or CO₂ injection

Constant Temperature and Humidity Chamber

Textiles Cloth Paper Films

For testing under constant temperature and humidity conditions

Temperature Range +20 °C to 60 °C
(-40 °C to 250 °C with no humidity control)

Humidity Range 40% to 95%

Refrigerator Type Environmental Temperature and Humidity Chamber



Optimal chamber for testing materials with mechanical properties sensitive to temperature and humidity effects, such as fibers, paper, or films.
Temperature regulation: Automatic control by heater and refrigerator

Adhesive Force and Friction Force Measurements

Grips

Adhesive tape Adhesive sheet

For adhesive tape peeling tests

Adhesive Tape Peeling Test Device



The sample table slides in synchronization with the upper grip movement to maintain a 90° peeling angle. Peeling test jig compliant with JIS Z0237 and JIS Z1528.

Grips

Vulcanized Rubber Thermoplastic Rubber

For adhesion testing of rubber

Rubber Adhesive Strength Test Device

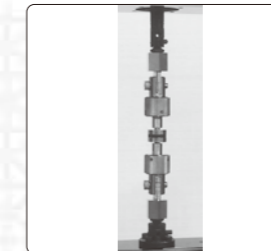

Conducts adhesion tests on rubber adhered to two parallel metal plates. Adhesion test jig compliant with JIS K6256, JIS K6250, and ASTM D429.

Grips

Plastics Films

For coefficient of friction measurements on plastics and films

Friction Modulus Test Device



For measurements of the coefficient of sliding friction between identical plastics or films or between different materials across the continuous range from static friction to dynamic friction. Two versions: compliant with JIS K7312 / ASTM 1894 and compliant with JIS K7125 / ISO 8295.

Jigs for Specific Specimen Shapes

Grips

Yarn Cord

For testing cord specimens



Pneumatic Capstan Type Grips for Yarn

These grips grip a yarn or cord specimen from the capstan (winch). The pneumatic operation allows application of an initial test force.

Grips

O-rings

For dedicated tensile testing of O-rings



1 kN Roller Type Grips

The O-ring is hooked onto rollers, which rotate during tensile testing. Conforms to JIS K6251, JIS K7312, ISO 37, and ASTM D412 test standards.

Specifications

Model		AGS-1N/2N/5NX			AGS-10N/20N/50NX			AGS-100NX	AGS-500NX	AGS-1kNX	AGS-5kNX	AGS-10kNX
Capacity		1N	2N	5N	10N	20N	50N	100N	500N	1kN	5kN	10kN
Loading Method		Direct high-precision constant speed strain control method via non-backlash ball screw drive										
Force Measurement	Accuracy	High-Precision Type (1/500, ±0.5%) Within ±0.5% indicated test force (at 1/500 to 1/1 load cell rating) Conforms to EN 10002-2 Grade 0.5, ISO 7500-1 Class 0.5, BS 1610 Class 0.5, and ASTM E4, JIS B7721 Class 0.5. (*1)										
		Standard-Precision Type (1/500, ±1%) Within ±1% indicated test force (at 1/500 to 1/1 load cell rating) Conforms to EN 10002-2 Grade 1, ISO 7500-1 Class 1, BS 1610 Class 1, and ASTM E4, JIS B7721 Class 1. (*1)										
	Calibration Automatic test force calibration: select tensile, compression, or tensile and compression											
Crosshead	Speed Range 0.001 to 1000 mm/min (stepless)											
	Max. Return Speed 1500 mm/min											
Crosshead Speed Accuracy (*2)		±0.1%										
Crosshead Speed and Permitted Test Force		To load cell capacity across entire speed range										
Crosshead – Table Distance (Tensile stroke) (*3)		1200mm										
Effective Test Width		425mm										
Crosshead Position Detection	Measurement Method Optical encoder											
	Display Method Digital display (display resolution: 0.001 mm)											
	Positional Accuracy ±0.1% indicated value or ±0.01 mm, whichever is larger											
Sampling Speed		1 ms max.										
Test Method Files		40 files (PC link: 20 files, standalone controller: 20 files)										
Standard Functions		<ul style="list-style-type: none"> •Automatic reading of load cell characteristic values •Test force display function, Stress display function- Stroke display function, Position display function •External analog output (2 channels) •External analog input (2 channels) •External digital input (2 channels) •Analog recorder (option) output •Dataletty (option) output <ul style="list-style-type: none"> •Automatic test force / stress control (Autotuning) •Automatic strain control (Autotuning) •Test force auto-zeroing •Test force auto-calibration •Break detection, auto-return •Safety guard to protect against flying debris, with interlock •Load cell overload detection •Touch-load detection function 										
Accessories	Load Cell (with CAL cable)											
	Others Power cable (2.5 m), power fuse, turning rod, cable clamps, instruction manual											
Dimensions and Weight		Standard type: 653 mm (W) x 520 mm (D) x 1603 mm (H), Approx. 85 kg 250 mm extension type: 653 mm (W) x 520 mm (D) x 1853 mm (H), Approx. 90 kg 500 mm extension type: 653 mm (W) x 520 mm (D) x 2103 mm (H), Approx. 95 kg										
Power Requirements		Single phase 100/120/220/240 V AC (switching type) 50/60 Hz 1.2 kVA Supply voltage fluctuations within ±10% of the set value. D-class (100 Ω max.) grounding resistance.										
Power consumption		300W										
Operating Environment		Temperature: 5 °C to 40 °C Humidity: 20% to 80% (no condensation) Floor vibrations: frequency 10 Hz max., amplitude 5 μm max.										

(*1) Official certification after installation is recommended to comply with EN 10002-2, ISO 7500-1, and ASTM E4 standards, JIS B7721.
 (*2) Crosshead speed accuracy is calculated from the crosshead travel within a prescribed time at a constant speed between 0.5 mm/minute and 500 mm/minute.
 (*3) The tensile stroke is the effective stroke when SCG (screw type flat grips) or MWG (non-shift wedge type grips) are mounted.
 (*4) TRAPEZIUM LITE X is needed for these functions.
 Note: Values stated in this catalog are based on measurements conducted according to separately defined inspection standards.

Kits Numbers According to AGS-X Capacity

(The kit includes AGS-X tester + load cell set + upper and lower joints.)

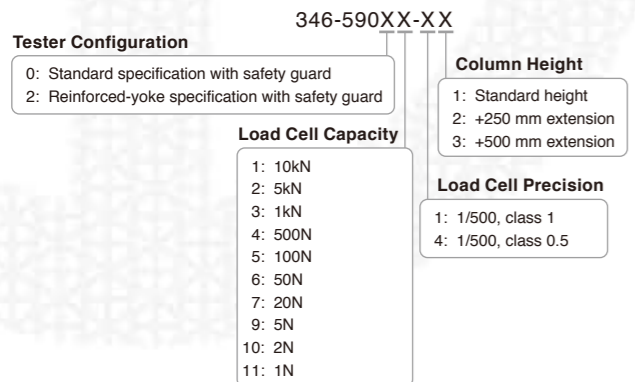

TRAPEZIUM LITE X PC Requirements	
OS	Windows Vista® Business or Windows XP® Professional
Monitor Resolution	1024 x 768 min.
CD/DVD Drive	CD-ROM drive
USB Port	USB 2.0/1.1

Options



Jog Controller
346-55922
The jog dial allows manual positioning of the crosshead.



Dataletty 551
348-34064
Test results printer.
Main printed items:
* Test force and stroke values at maximum force
* Stroke values at breaking point



Control I/O Expansion Box
346-55920-01
Expands the number of control I/O ports to four ports. Multiple options can be simultaneously connected to the control I/O ports.



Analog Recorder
X-T recorder 346-59210-01
Plots test force – time curves.
X-Y recorder 346-51736-01
Plots test force – time curves and test force – stroke curves.



Sensor I/O Expansion Box
346-55920-02
Expands the number of sensor I/O ports to two ports. Multiple options can be simultaneously connected to the sensor I/O ports. BNC cables can be connected to the analog I/O ports (2 ports each).



Power Cable
EU specification (VDE standard)
348-34063-03
Chinese specification (GB standard)
348-34063-02
Japanese, N. American specification (UL, CSA, PSE standards)
348-34063-01 is supplied as standard.

Other options are also available. For details, refer to the separate catalog (Shimadzu Autograph Optional Accessories).

Expanded Tester Series

Reinforced Yoke Specification
Permits tensile testing in the download direction.



Extended Column Specification
For testing with a longer test stroke.



Installation Space (Top View)

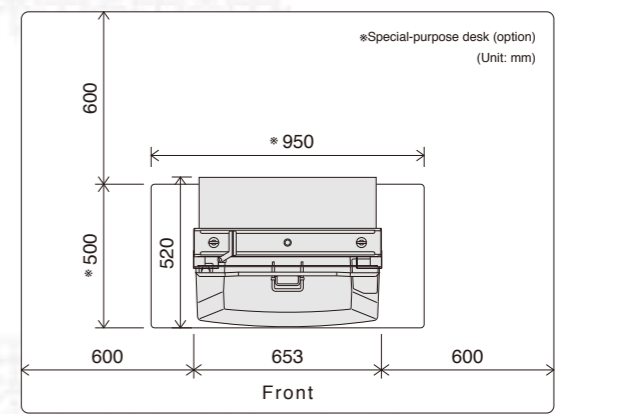

* Missing numbers for tester configuration and load cell precision are reserved for future use.
 * When the number of digits of Load Cell Capacity exceeds one, add 1 to Tester Configuration value.